

AD1 Area Drain with ADA Grate

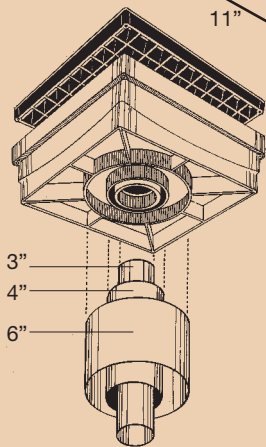

Choice of three size drain pipes.

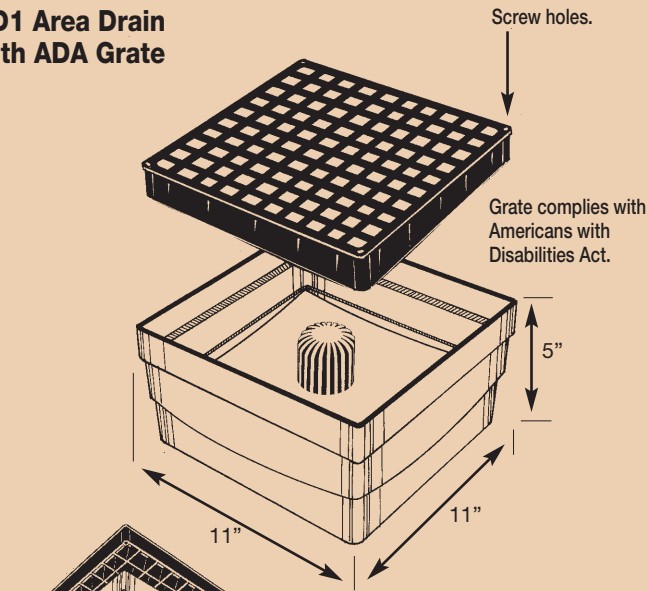
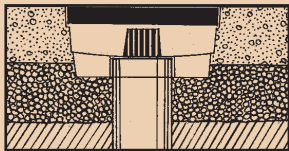

- **Rugged, non-corrosive**
Molded of gray High-Density Polyethylene. Ribbed bottom provides exceptional compression strength.
- **Atrium Drain**
Drain hole is protected by a 1-3/4" high atrium screen. A build-up of small debris won't stop the flow.
- **Steady Flow**
The contoured bottom directs all water to the drain. Standing water is eliminated.
- **Easily installed - anywhere!**
Only 5" deep. Easy to handle and usable with 3", 4" or 6" pipe. No pipe fitting needed.
- **Comes Complete**
Price includes a heavy duty ADA compliant grate. No extras required.

2-Hole Drain Sumps

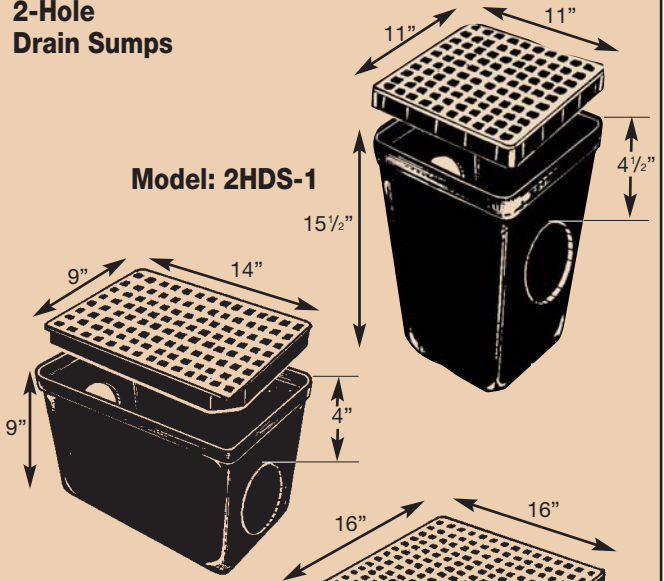

Model: 2HDS-2

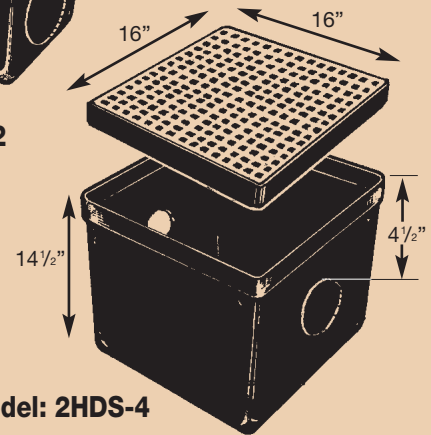

Model: 2HDS-4

All Tuf-Tite Drain Sumps are injection molded from non-corrosive High Density Polyethylene. Select a 2, 3, or 4-hole Drain Sump with an ADA approved Grate and your choice of 3 snap-in watertight fittings.

- S-35 Yellow Seal for thin wall pipe.
- S-40 Blue Seal for Schedule 40 pipe.
- P-10 Plug for unused holes.



Water-tight Lids and Risers by Tuf-Tite®

